



***Meitheal na Gaoithe
Annual Conference
Thurles***

**Jonathan O'Sullivan
SEMO Manager Market Operations
2nd May 2008**



Wind in the SEM

- Basic overview SEM
 - Market Structure
 - Market Design

- Concepts of Energy Payments
 - Specifics for wind
 - Unit Classification
 - Constraints

- Concepts for Capacity Payments

- Performance of SEM to date
 - Prices
 - Typical Generator Market Schedules
 - Payments

- Registration
 - Who to talk to – what to do



Market Structure Monopoly

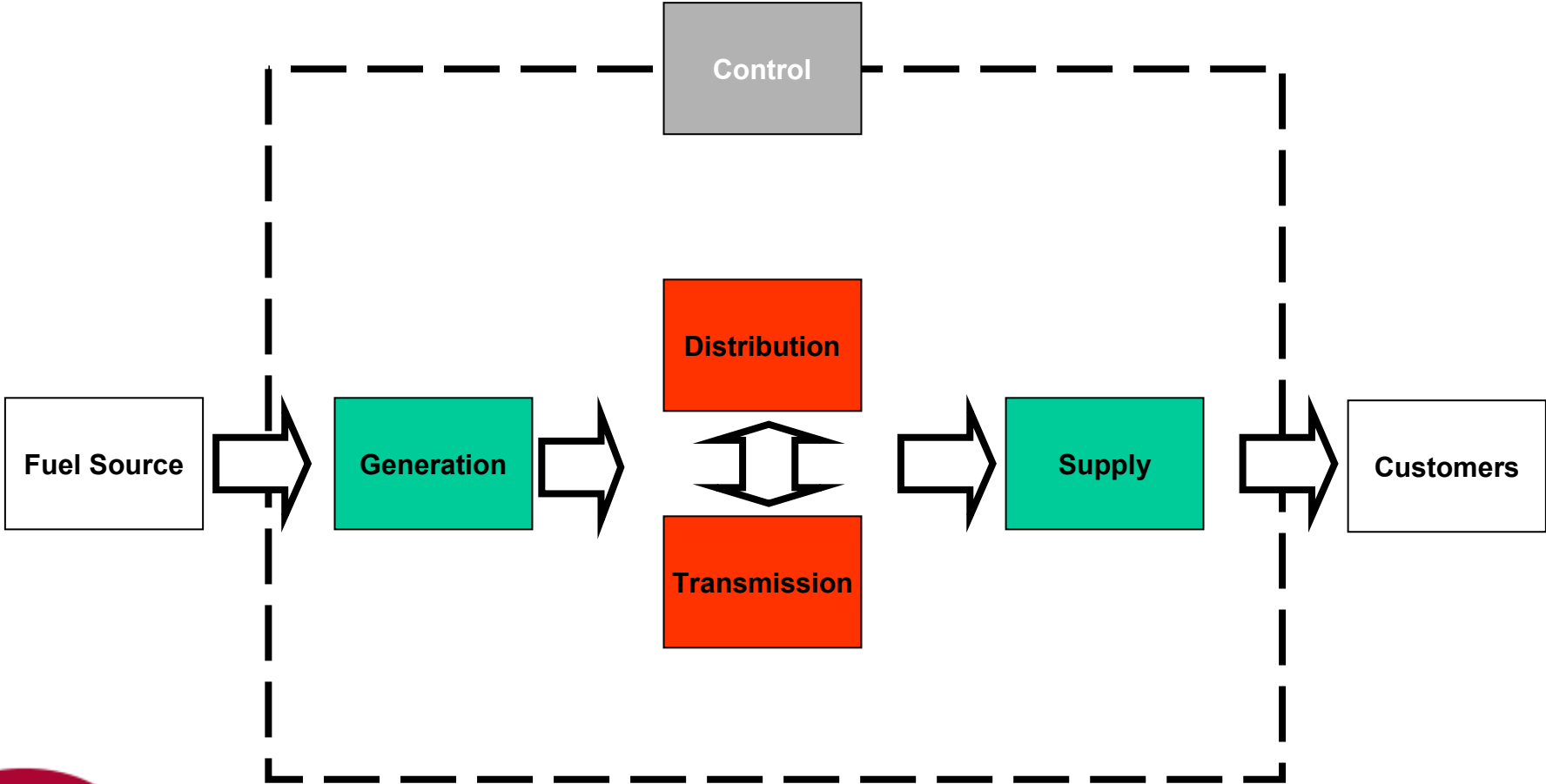

Market Structure De-regulated

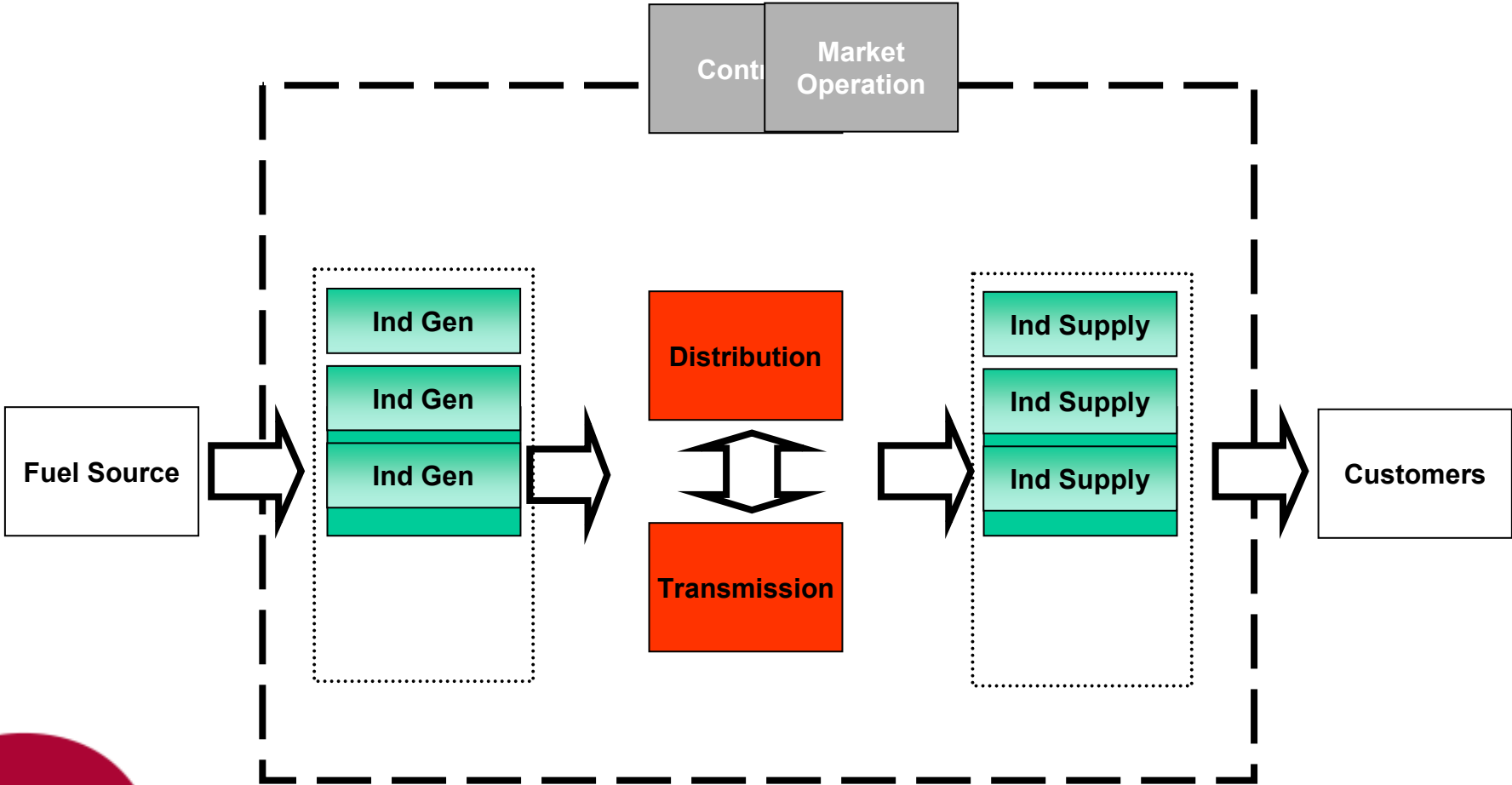

Market Structure

Single Electricity Market

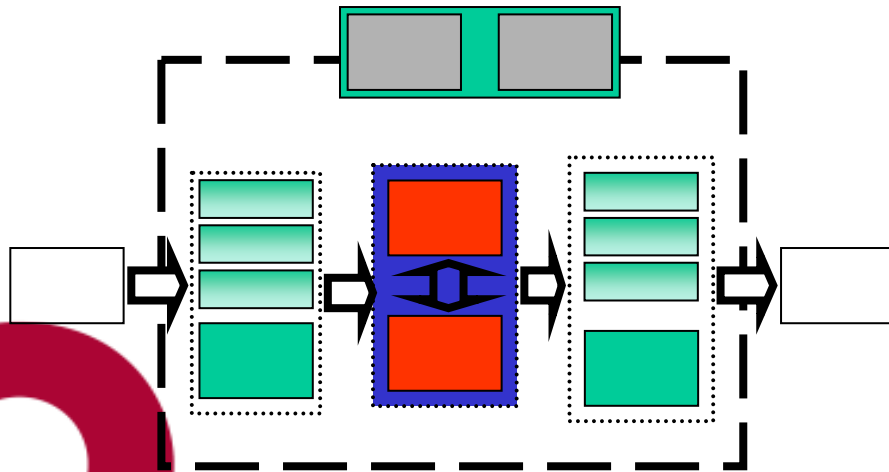
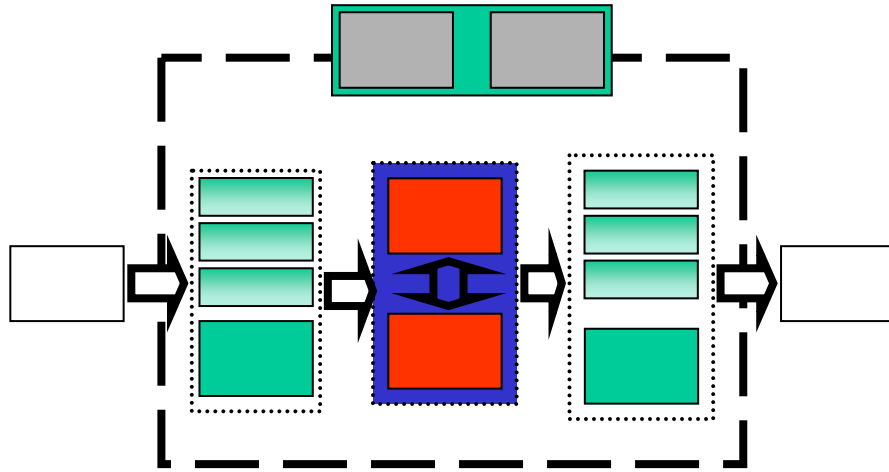

Market Structure

Single Electricity Market

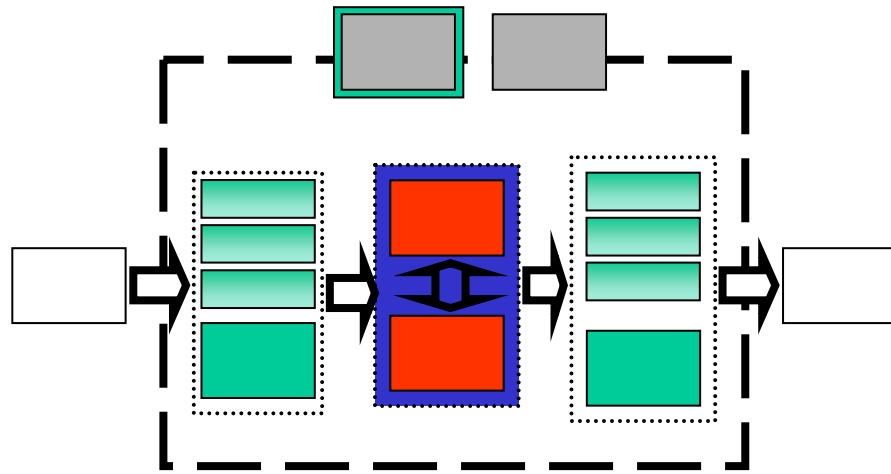

SEM Operator

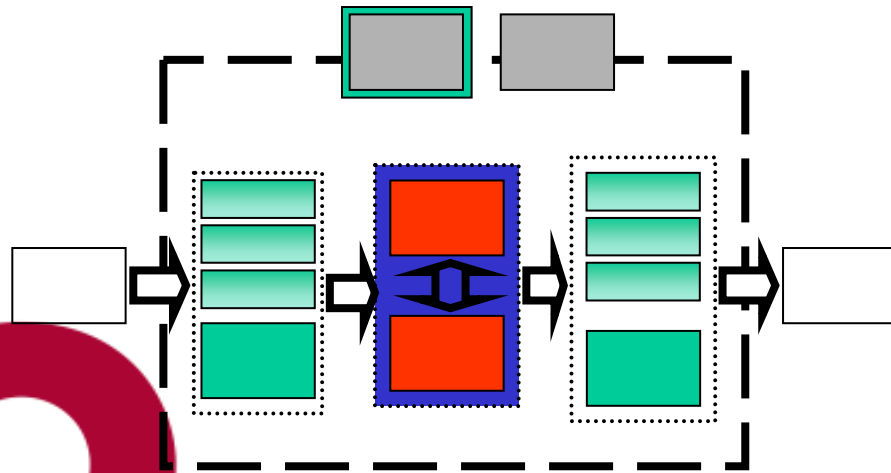

Market Structure Single Electricity Market

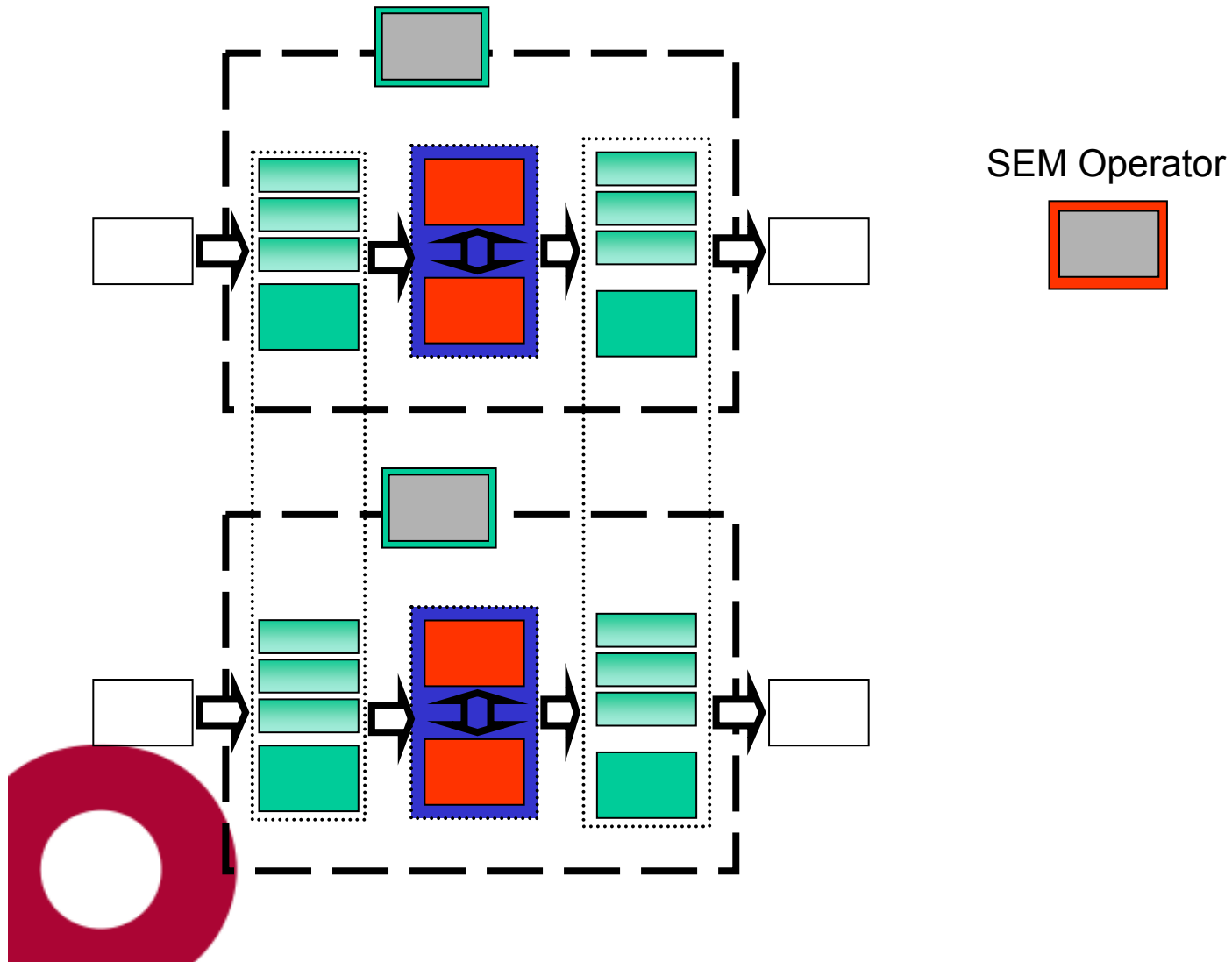

Market Design: Old Market (TESS) De-centralised Market

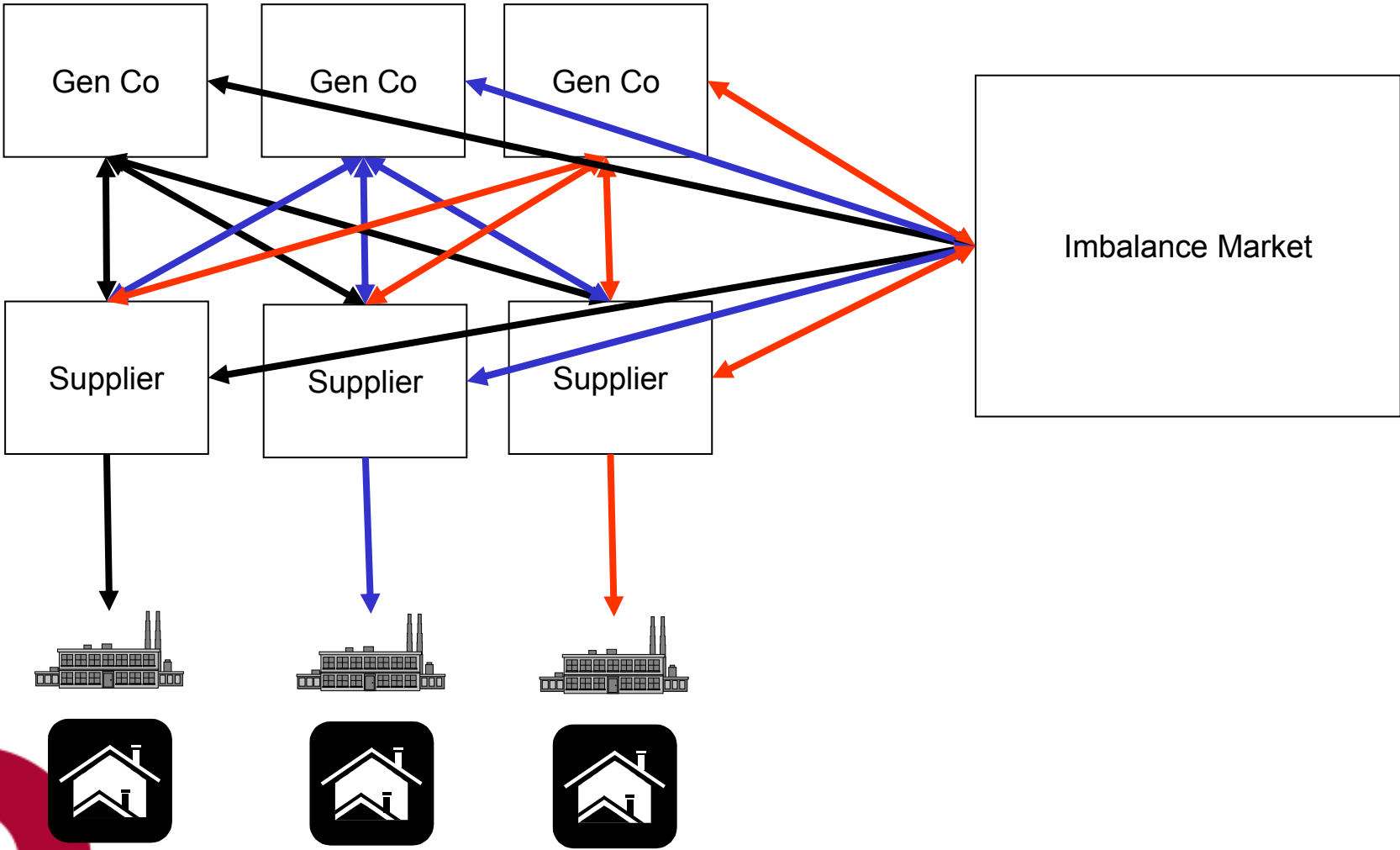

Market Design: SEM Centralised Market

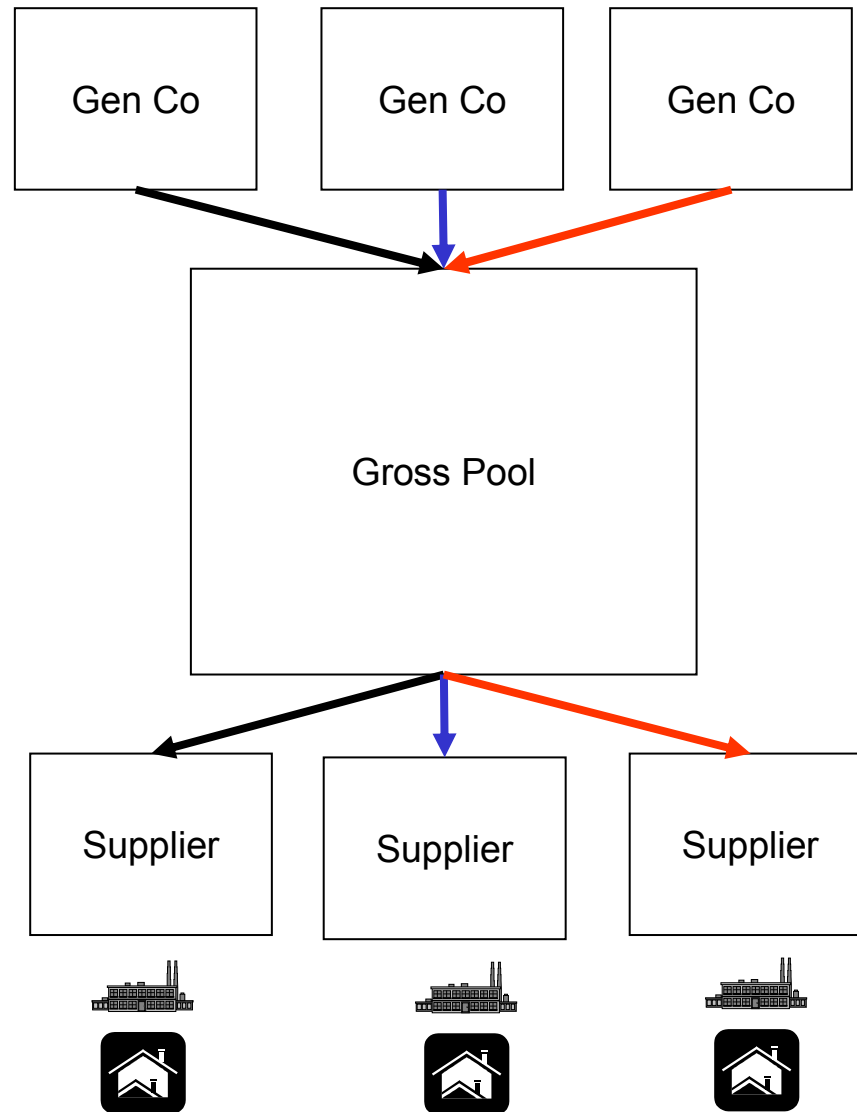

Market Design: SEM Centralised Market

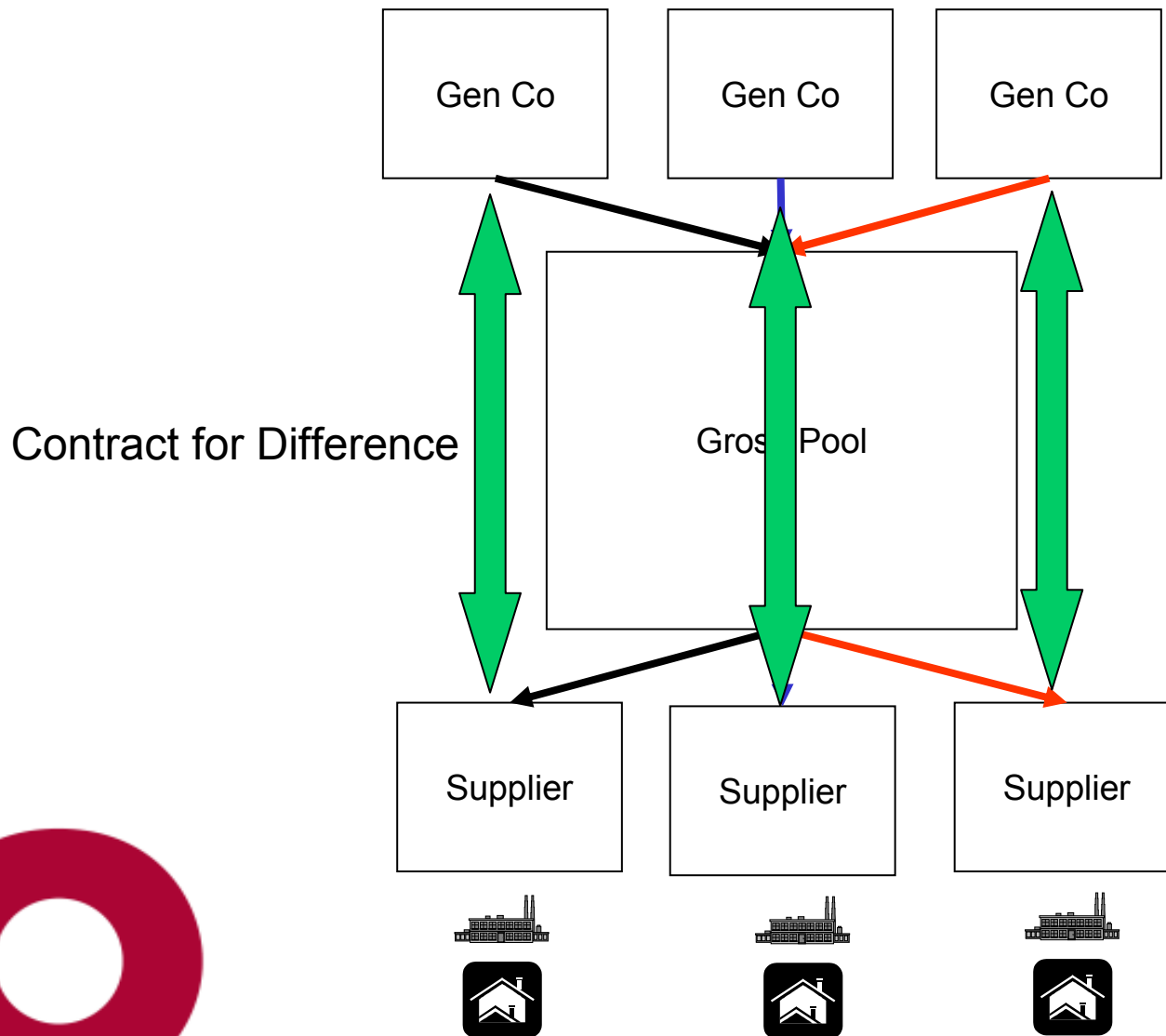

Market Design: Energy Payments

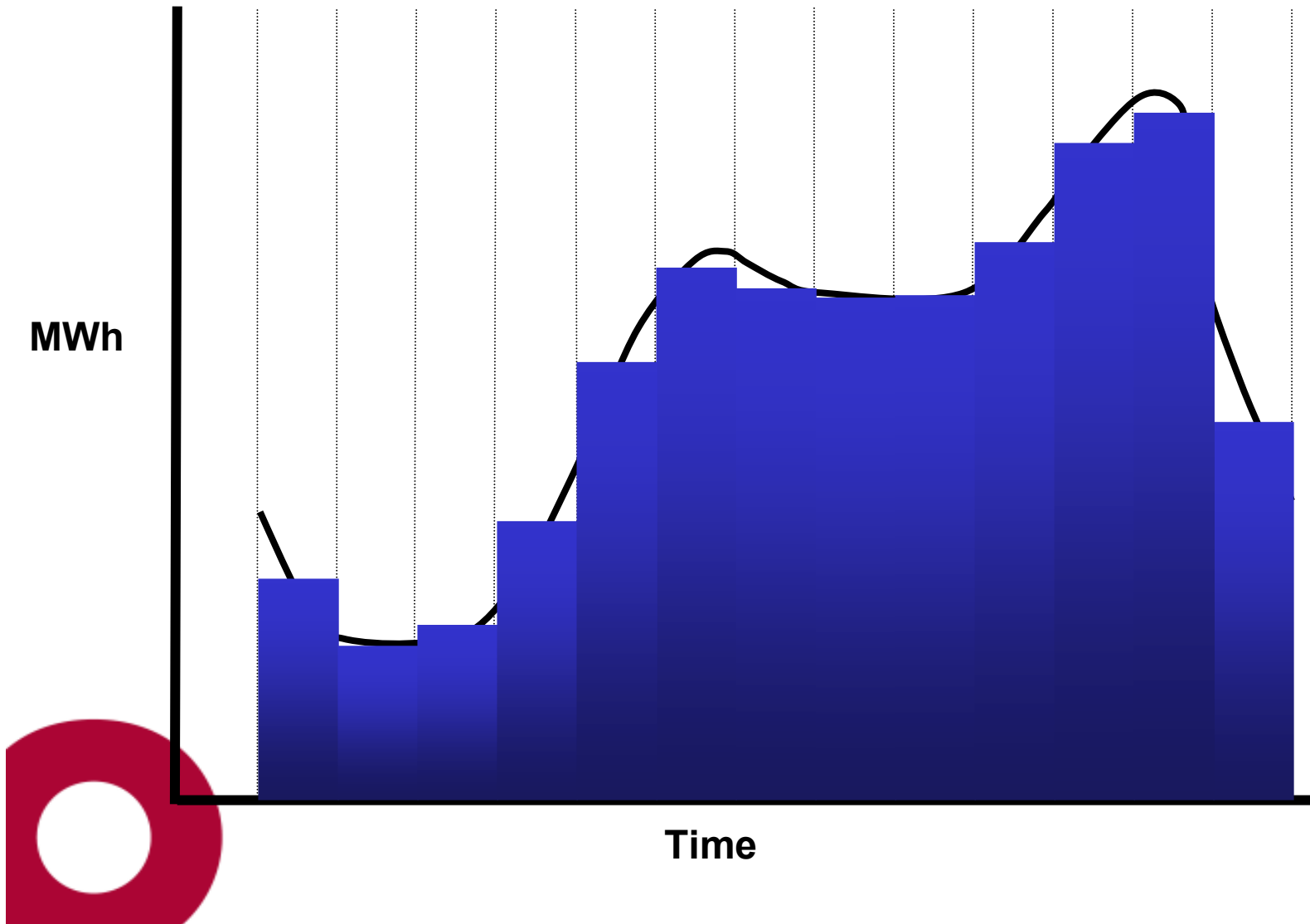

Wind in the SEM

- Classification of Units
 - Predictable Price Maker
 - Variable Price Maker
 - Predictable Price Taker
 - Variable Price Taker
 - Autonomous

- Autonomous – Small Windfarms Non Dispatchable
 - Energy Payments $SMP * MSQ$
 $MSQ = \text{Metered Output}$

- Variable Price Taker – Large Windfarms - Constrainable
 - Energy Payments $SMP * MSQ$
 $MSQ = \text{metered output or availability}$
 - Constraint Payments
 - Instructed Imbalance
 - Uninstructed Imbalance



Variable Price Taker Availability Profile

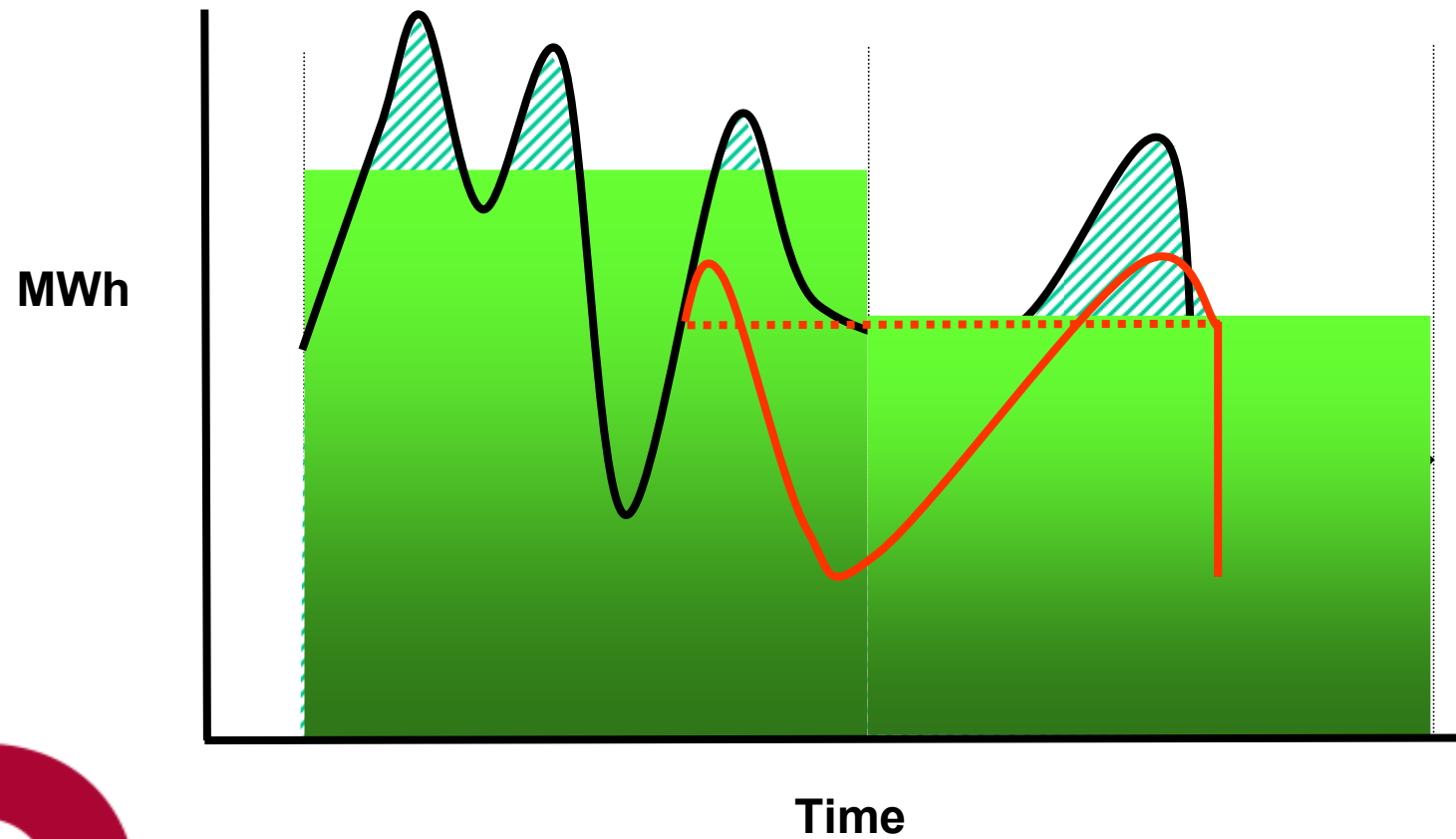

Variable Price Taker Dispatch Quantities

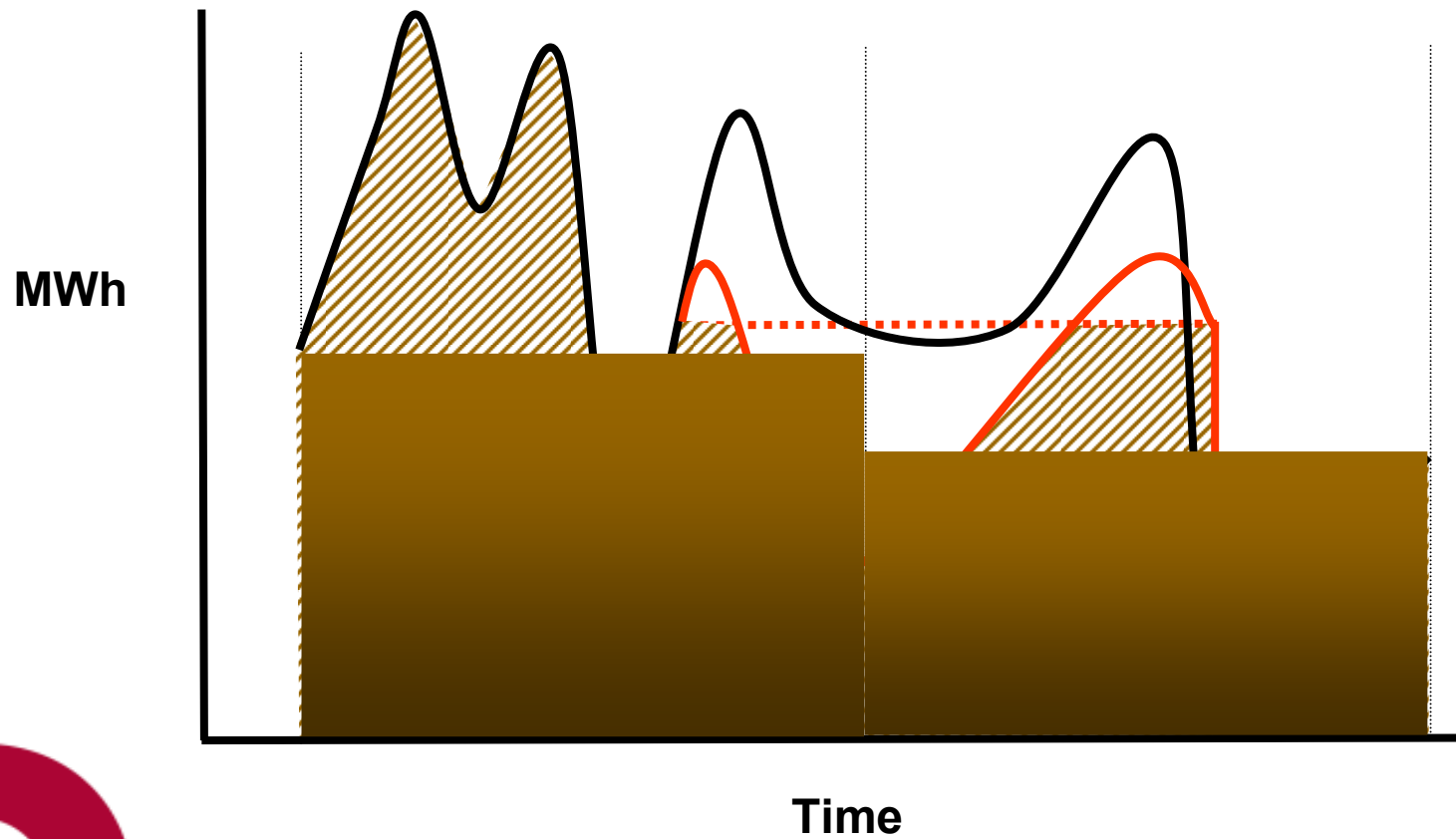

Variable Price Taker Metered Quantities

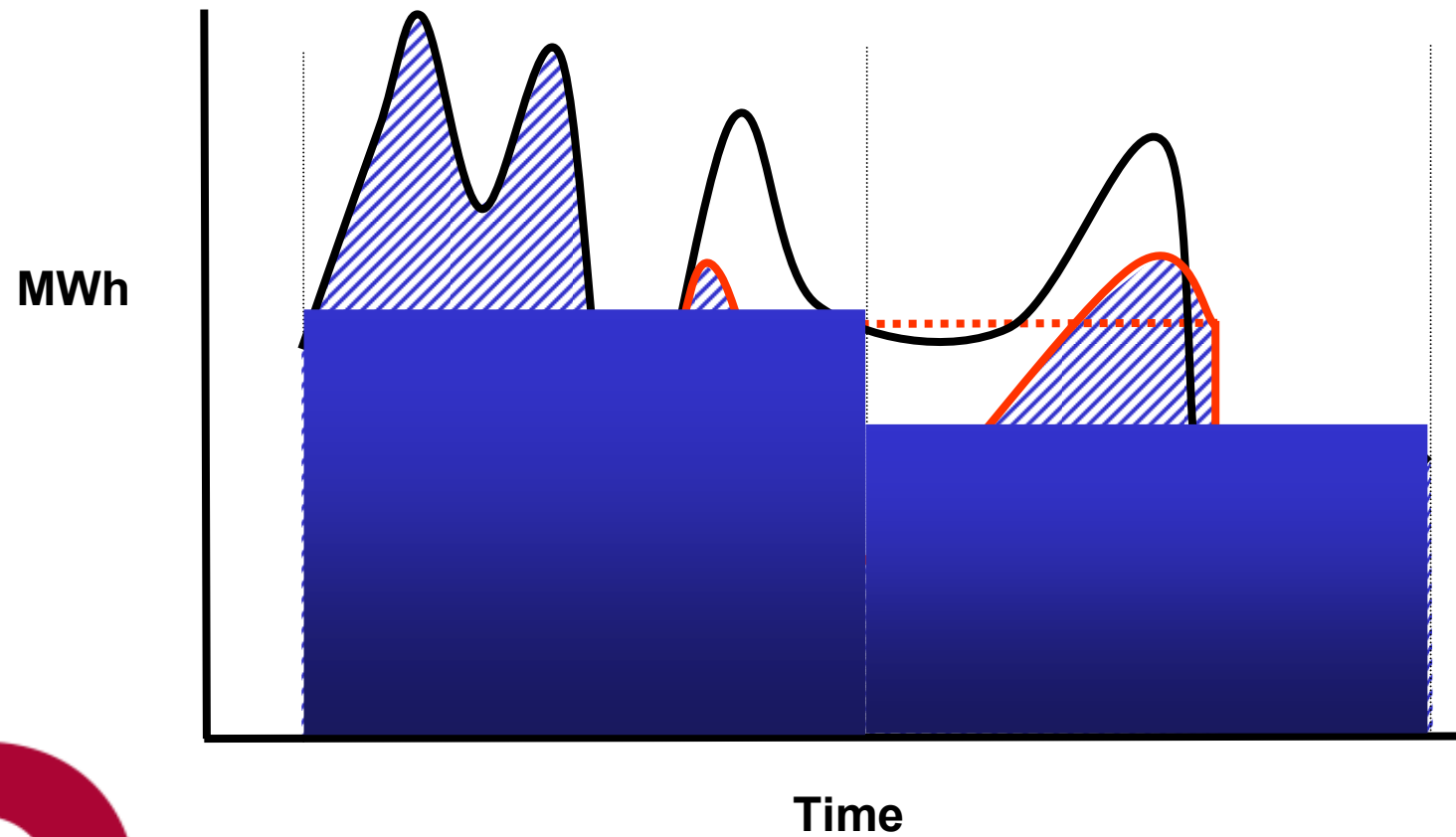

Variable Price Taker Energy and Constraint Payments

Availability (EA)	Dispatch Quantities (DQ)	Metered Quantity (MG)	MSQ
100	80	75	100

$$\begin{aligned}\text{Energy Payments} &= \text{MSQ} * \text{SMP} \\ &= 100 * \text{SMP}\end{aligned}$$

$$\begin{aligned}\text{Constraint} &= (\text{DQ} - \text{MSQ}) * \text{DECP} \\ &= (80 - 100) * \text{DECP} \\ &= (80 - 100) * 0 = 0\end{aligned}$$

$$\begin{aligned}\text{Uninstructed Imbalance} &= f(\text{MG} - \text{DQ}) \\ &= f(75 - 80) = f(-5)\end{aligned}$$



Capacity Payment Mechanism

- Reward for providing capacity
 - Assists recovery of investment long term
- Paid to all generators who provide capacity
 - Currently no capacity payment for wind
- Combination of
 - Forecasted value of when need for capacity
 - Actual availability on the day
- Monthly settled



Capacity Payment Mechanism

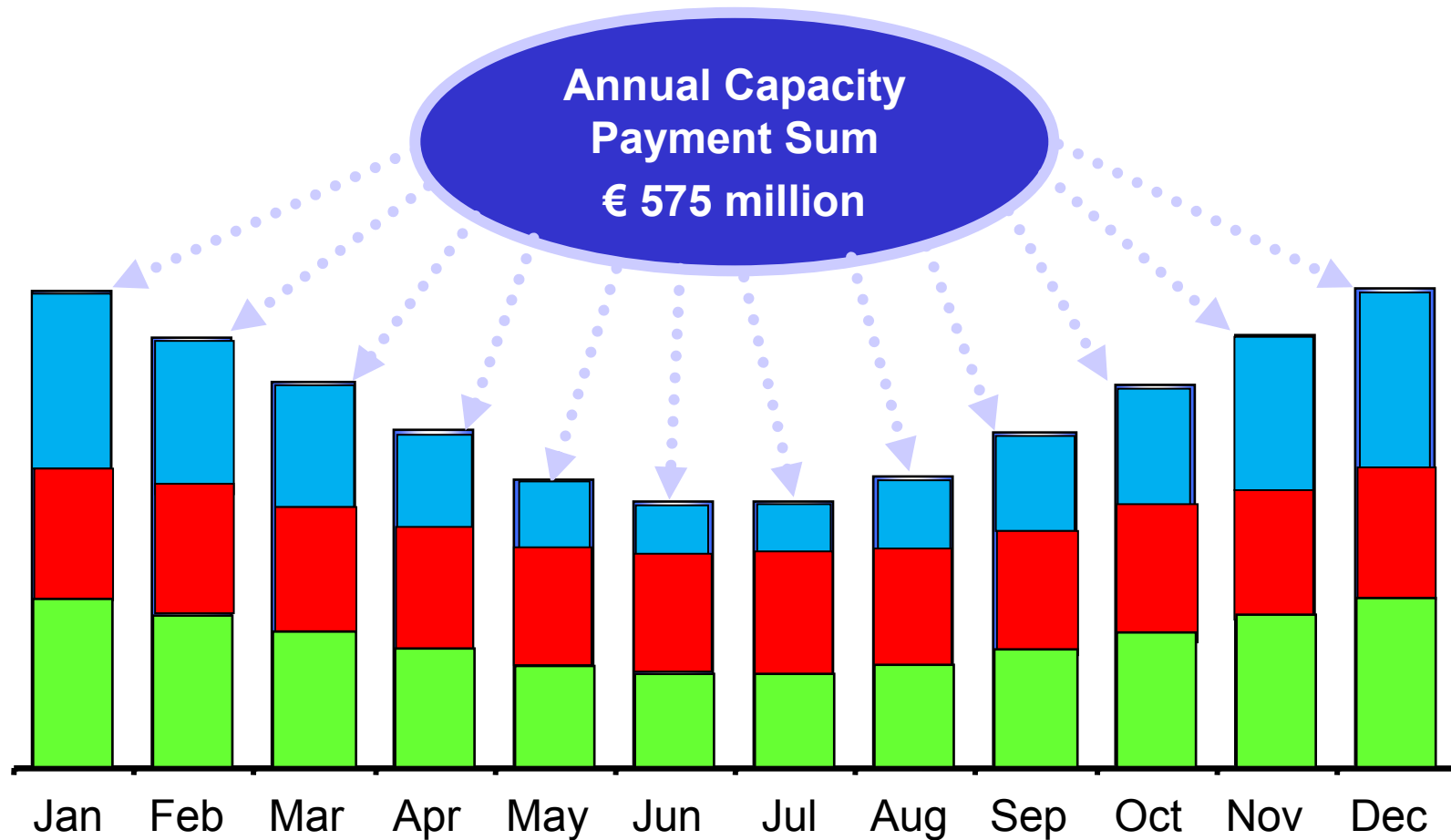

Capacity Mechanism Payment

- Capacity payment for a unit
 - All the monthly pot will be paid out
 - Allocated proportion of the payment sum
 - Allocation based on
 - Amount of capacity offered by the unit in that period
 - Price scaler of capacity being offered by the unit in a period
 - Value of capacity in a period

- Amount of Capacity
 - For all units this is the availability
 - Wind available approx 30% of their registered capacity
 - Large dispatchable units available approx 90% of their registered capacity

 - Price Scaler
 - Lowers price of capacity when SMP high
 - price has a weighted element for uncommitted availability
 - Wind will not have any uncommitted availability



Value of Capacity Fixed Capacity

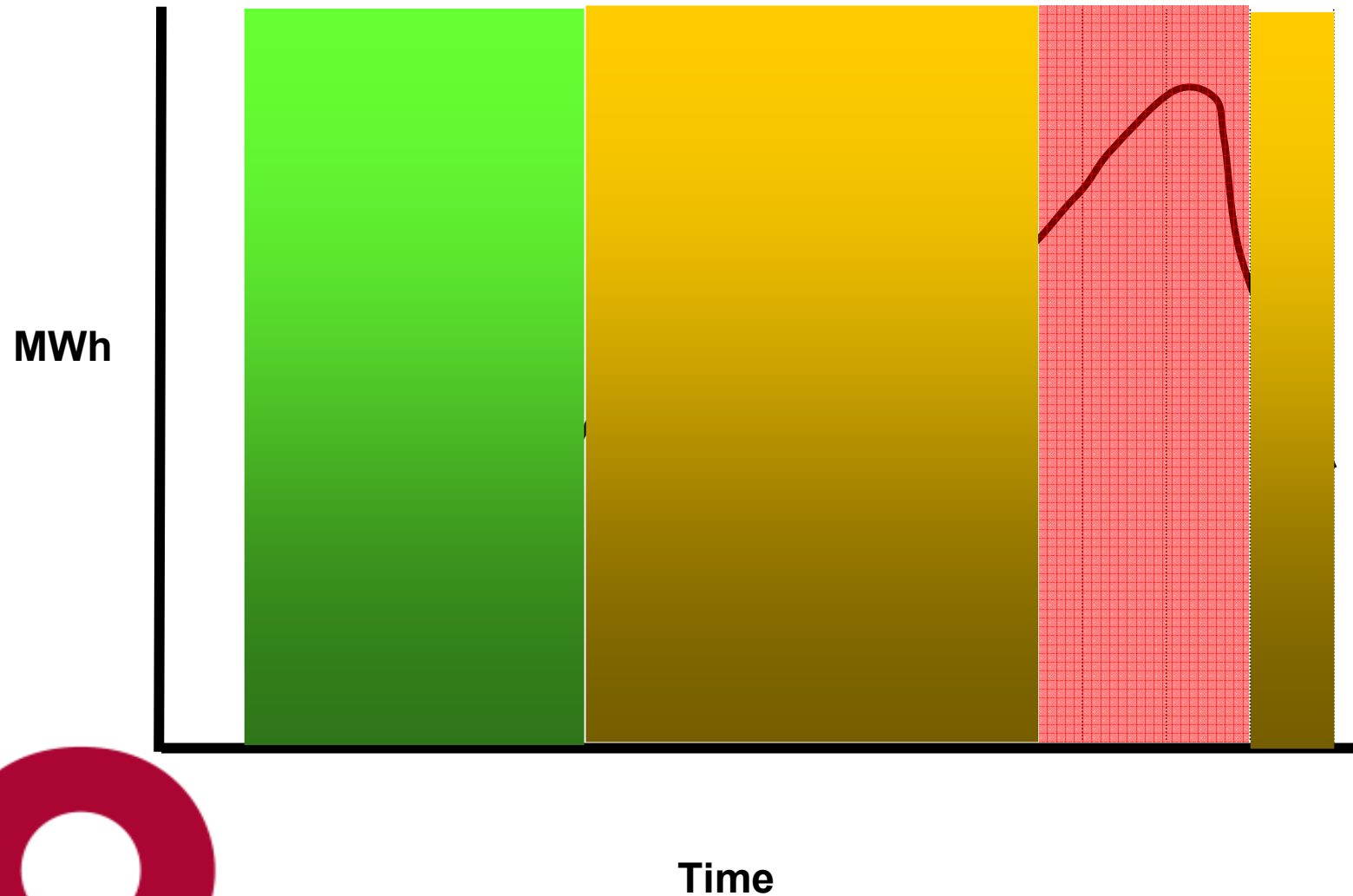

Value of Capacity Month Ahead Ex-Ante

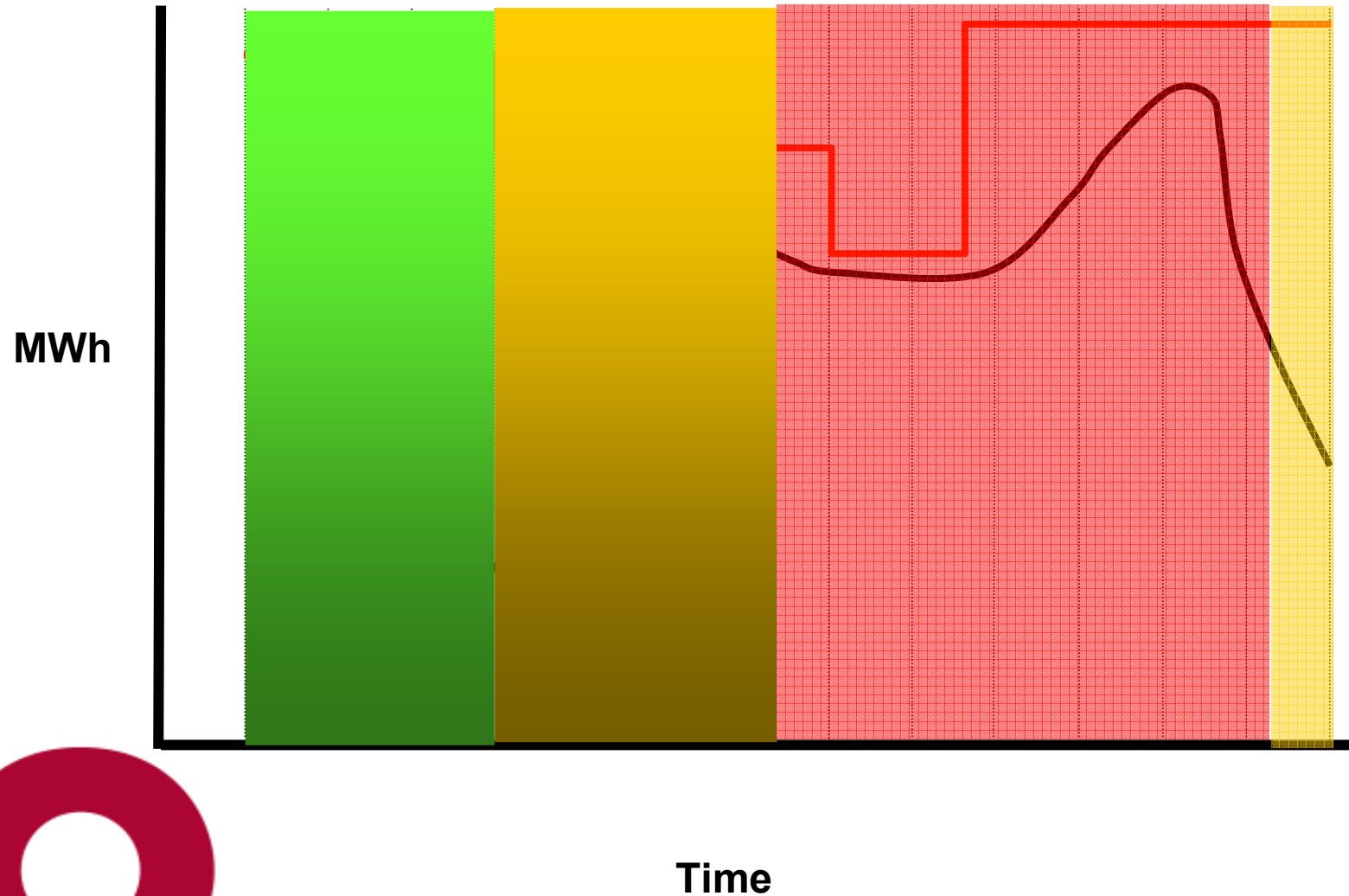

Value of Capacity Ex-Post

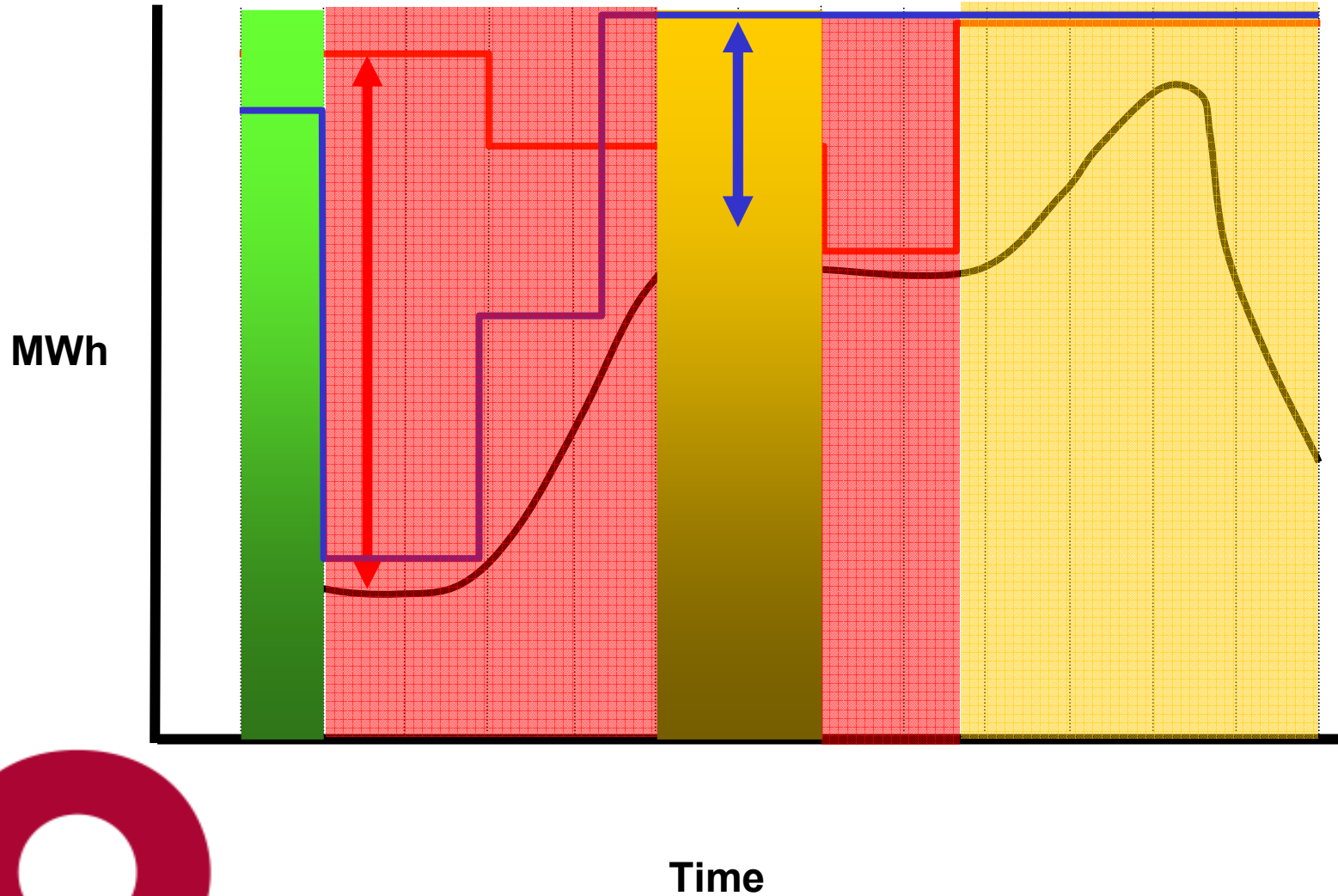

Capacity Payment Calculation

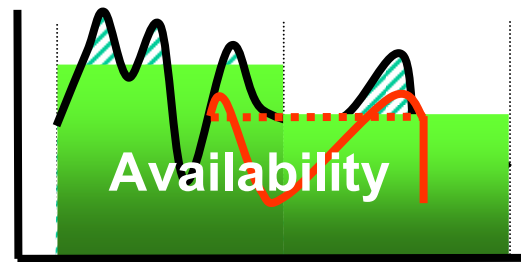

X

Price
Scaler

X

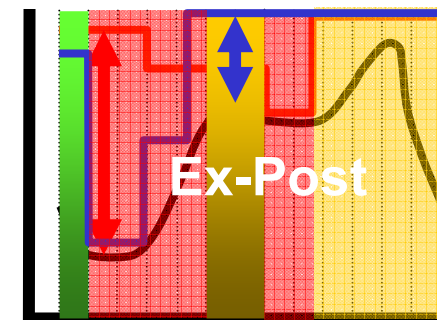
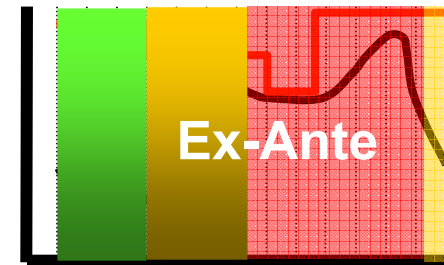
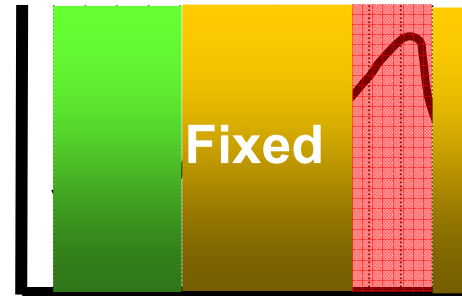

=
Capacity
Payment



Overview of SEM performance

- Single Electricity Market
 - Went live 1st November 2007
 - Gross Pool
 - Carbon included in bids from 1st Jan 2008

- Capacity Payments
 - Wind included in the mechanism

- Additional Support Mechanisms



Average System Marginal Price in the SEM

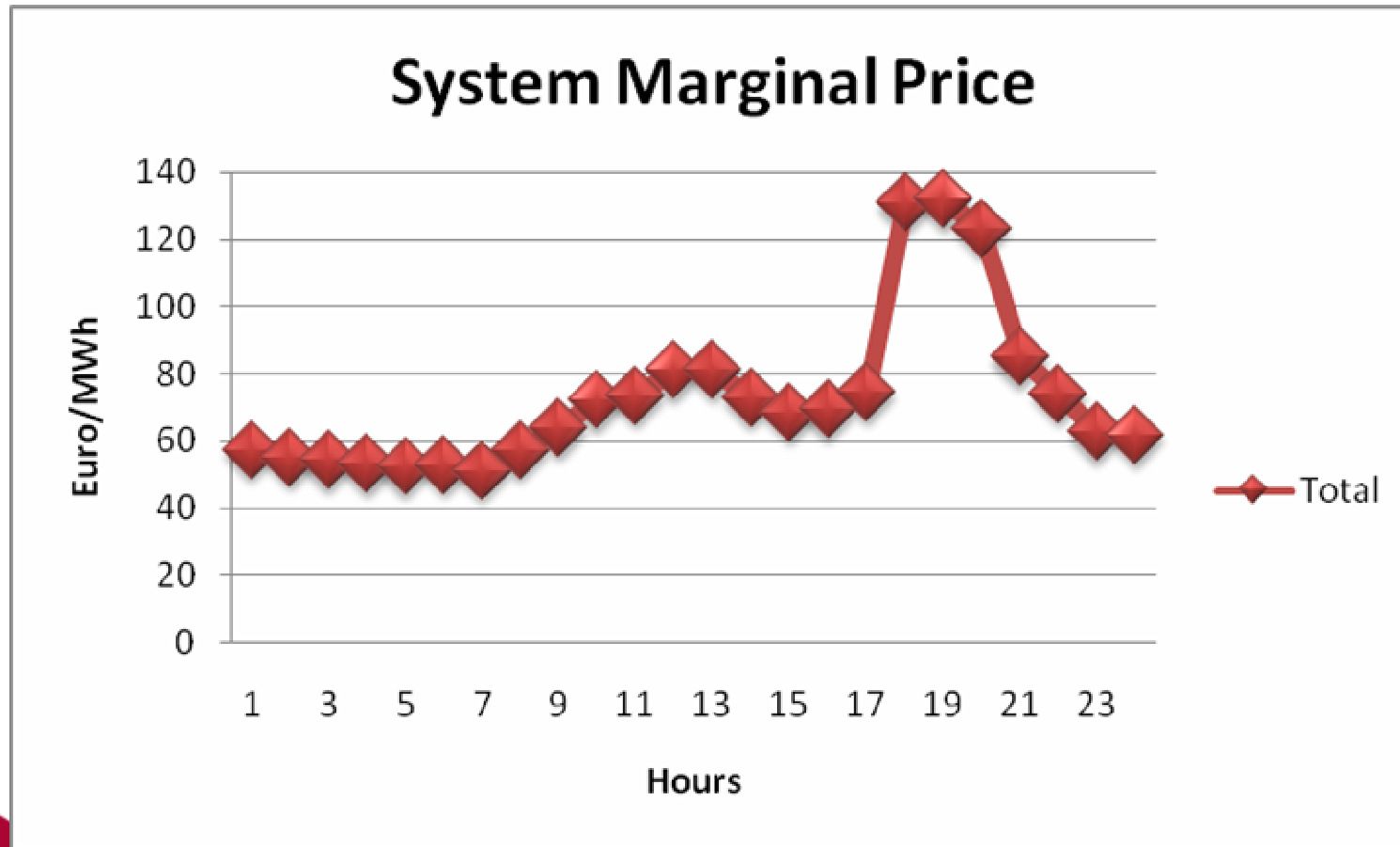

Average Market Schedule for CCGT in SEM

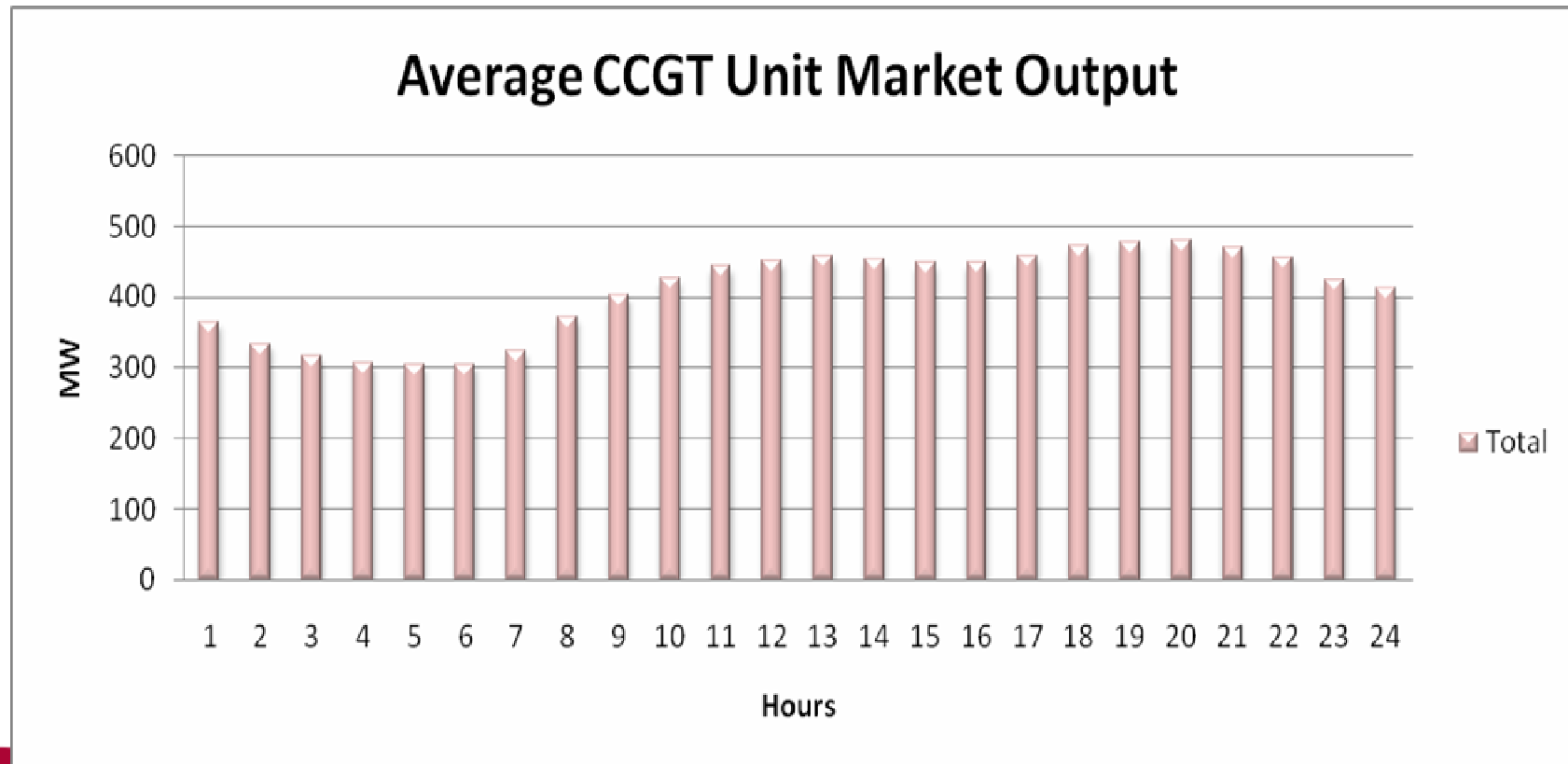

Average Market Schedule for Oil Units in SEM

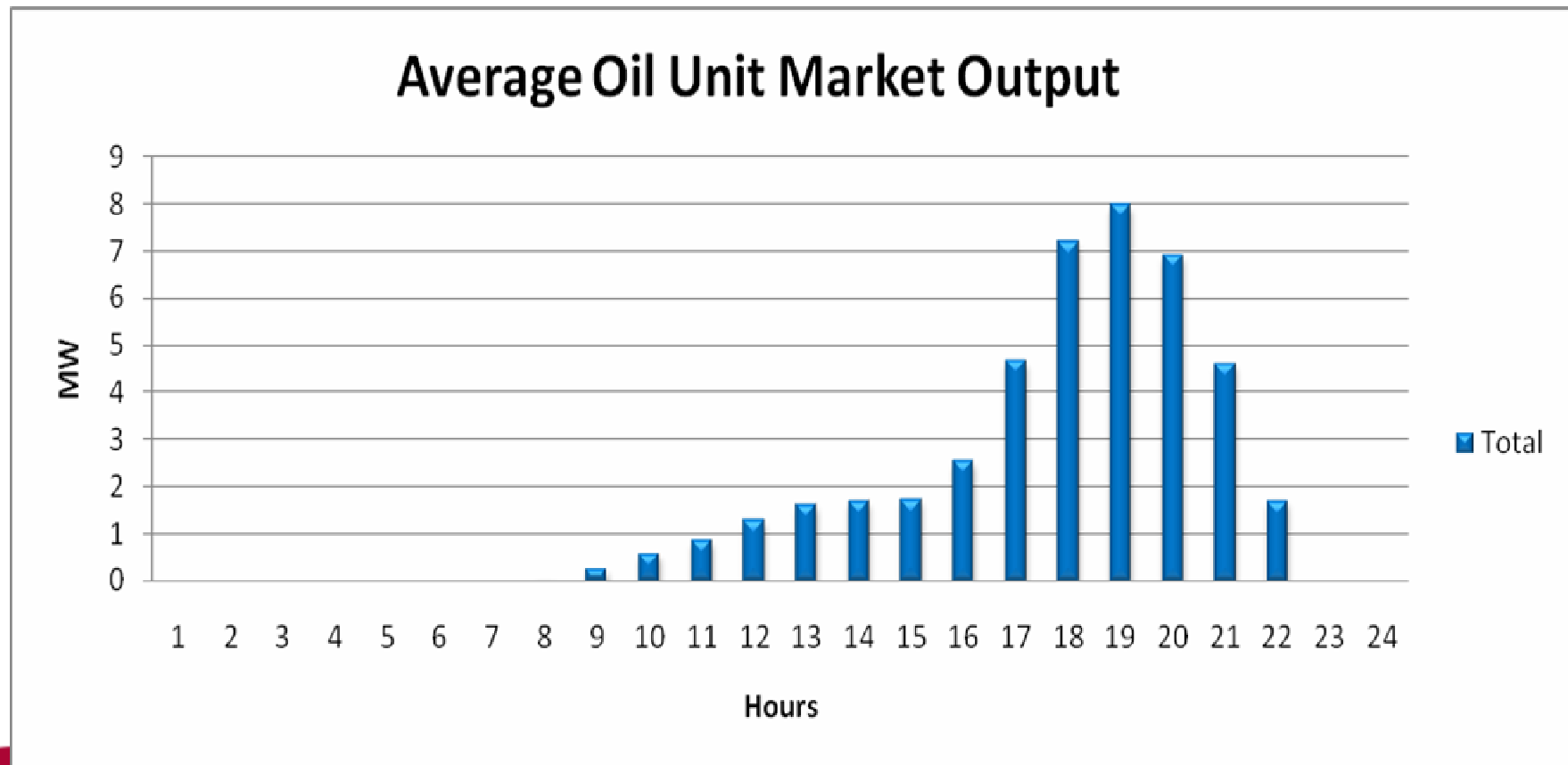

Average Market Schedule for OCGT in SEM

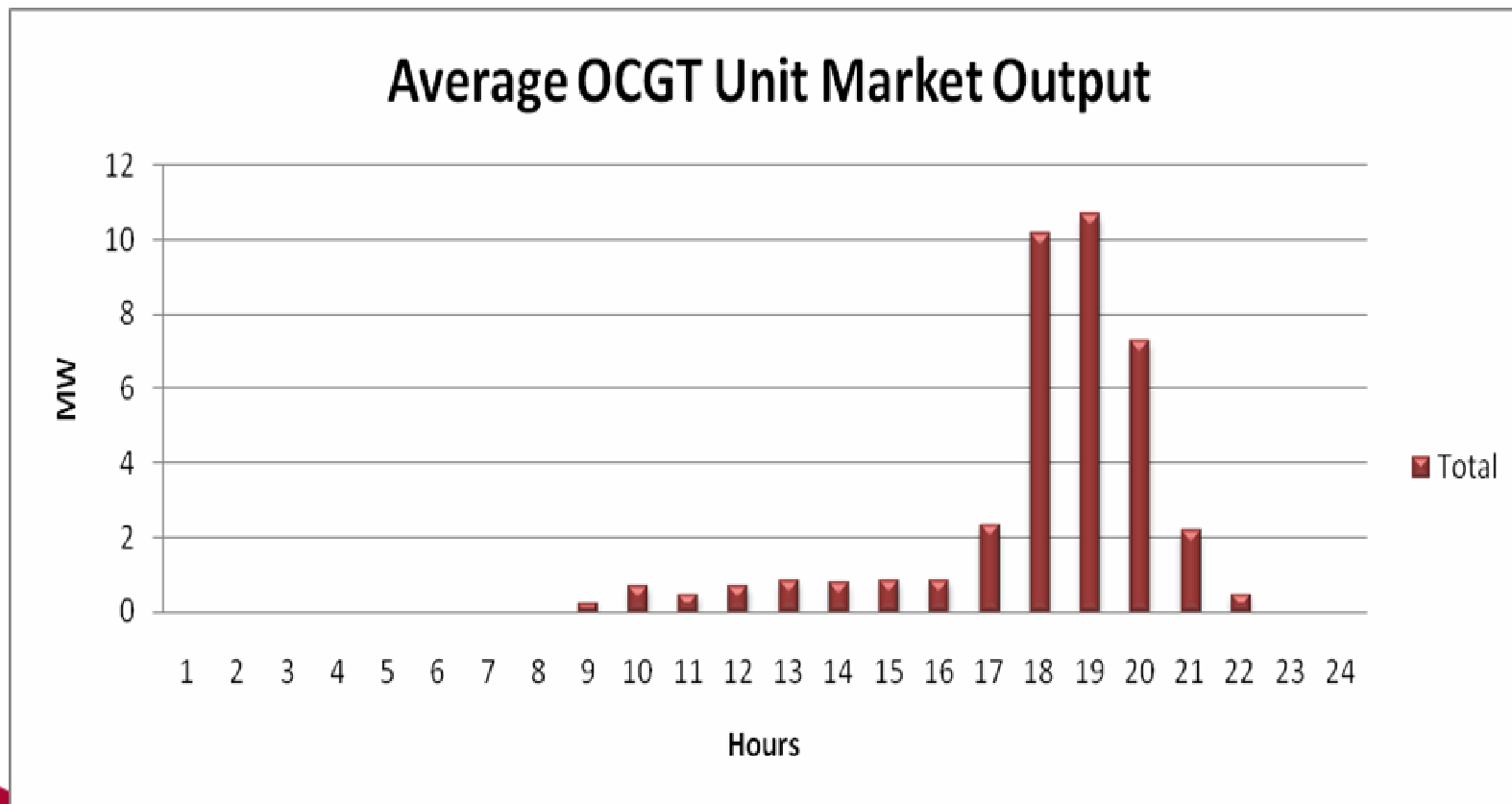

Average Market Schedule for Hydro in SEM

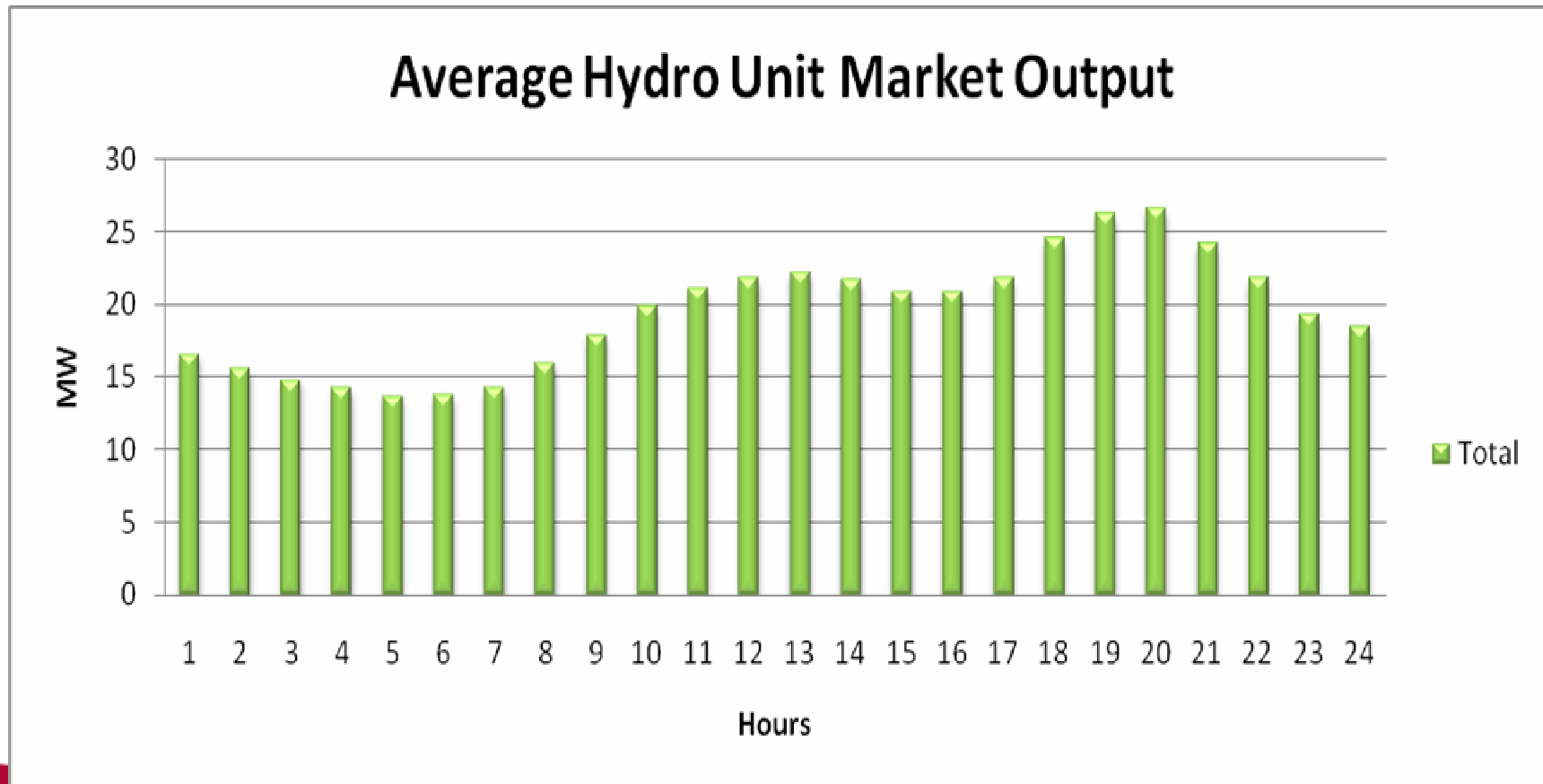

Average Market Schedule for Wind in SEM

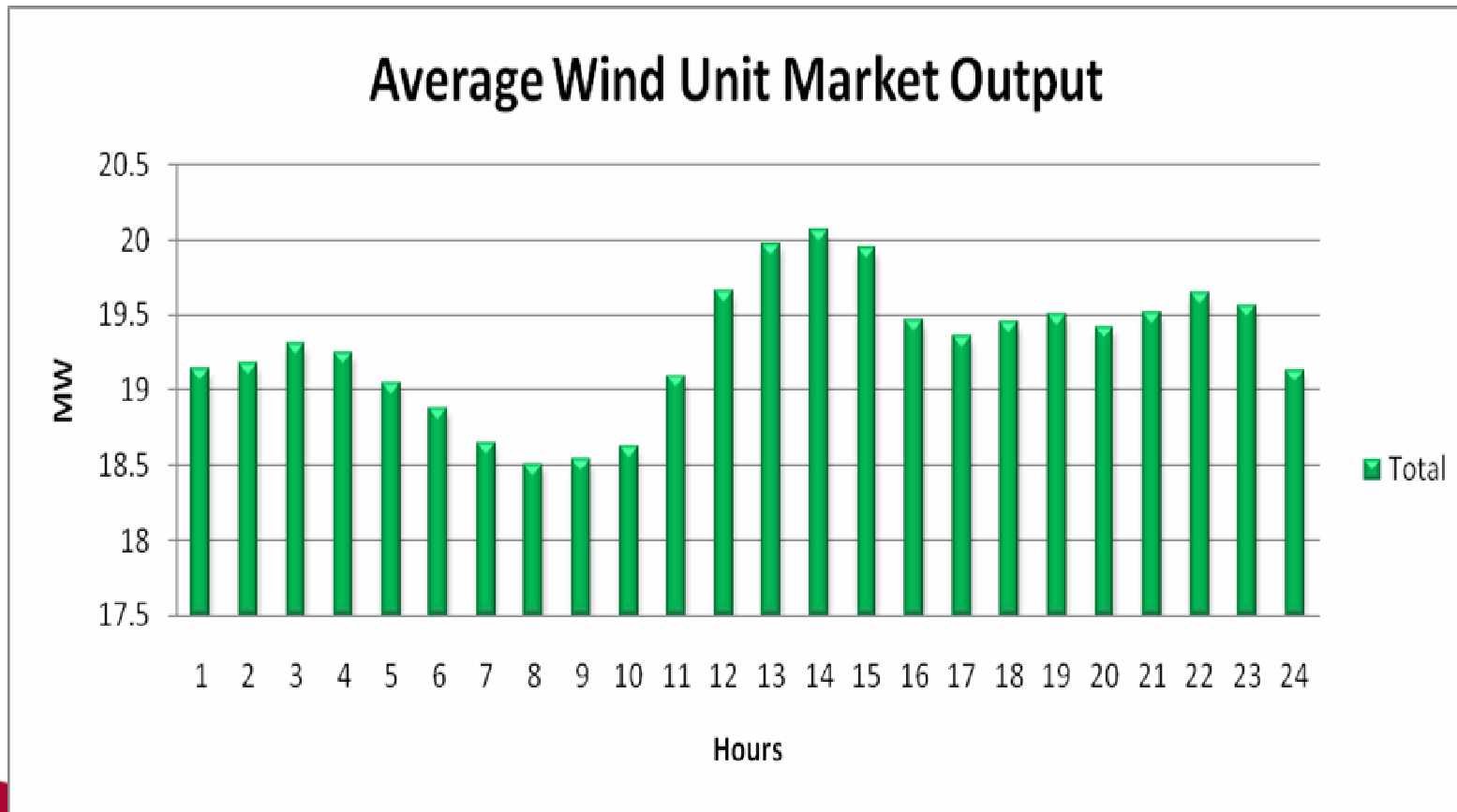

Average Load Weighted Price for Wind in SEM

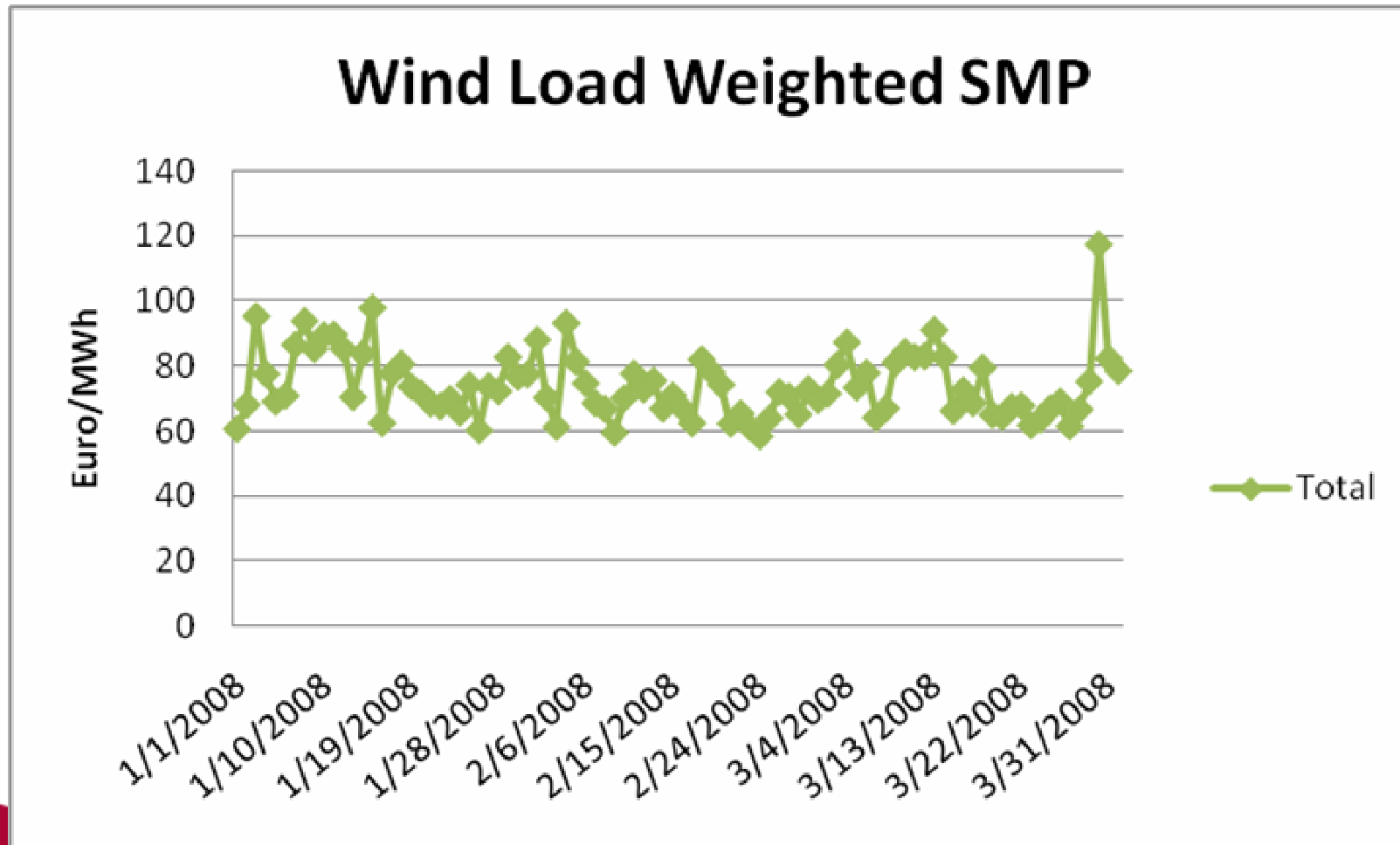

Average Load Weighted Price by Type in SEM (when on in market)

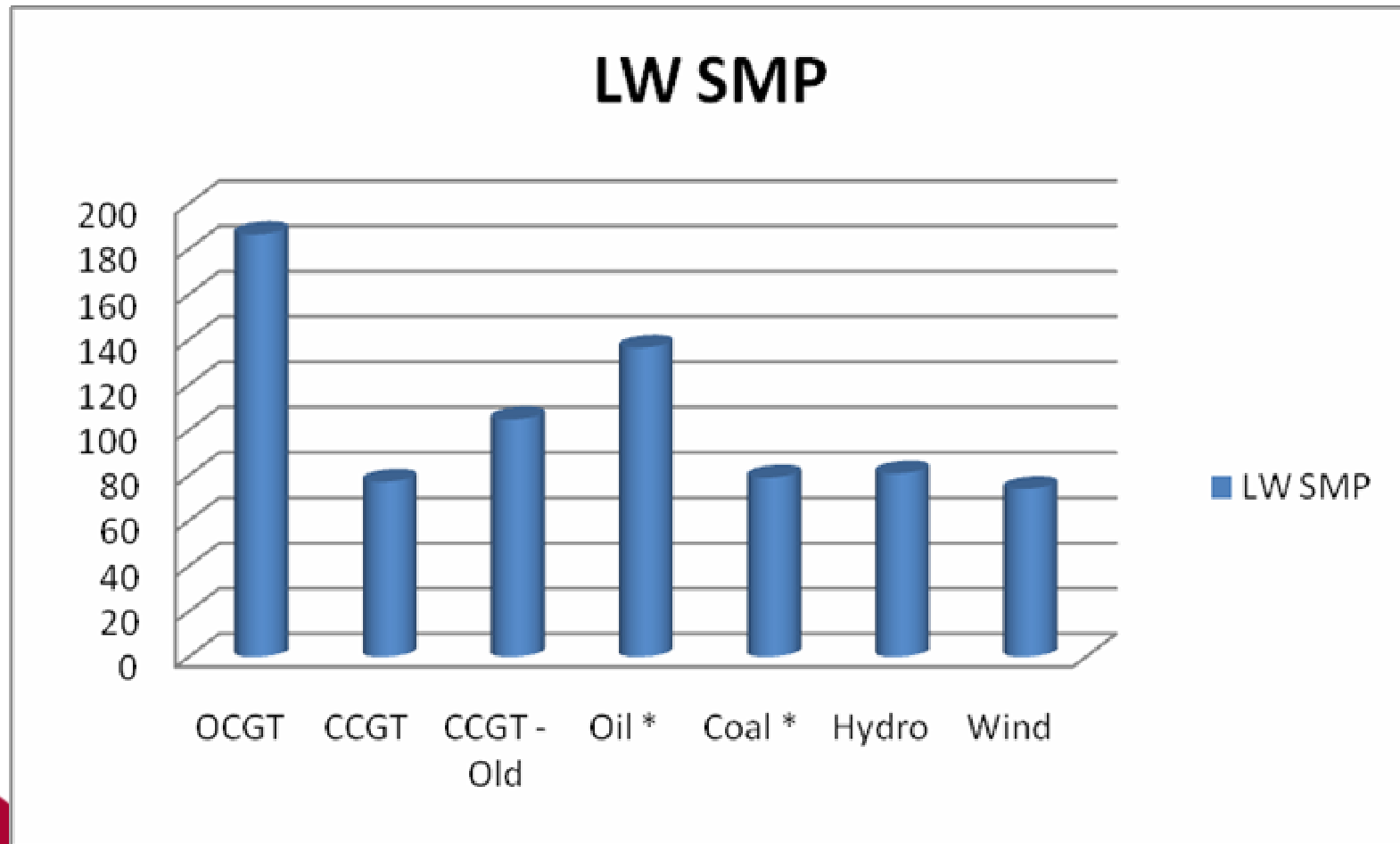

Inframarginal Rent in the SEM energy market

Figures are based on 1st Qtr 2008

Plant Type	Revenue	Costs *	Rent	Percentage
CCGT	€ 391,811,510	€ 180,626,349	€ 211,185,160	54%
Coal	€ 123,796,651	€ 98,751,823	€ 25,044,828	20%
Natural Gas	€ 31,622,129	€ 17,916,116	€ 13,706,013	43%
OCGT	€ 3,189,615	€ 1,812,532	€ 1,377,083	43%
Oil	€ 2,936,422	€ 2,309,811	€ 626,611	21%
Hydro	€ 25,691,843	€ 83,282	€ 25,608,561	N/A
Wind	€ 44,431,234	€ -	€ 44,431,256	N/A



* based on the bid offers submitted to SEM and the market schedule

Payments from Capacity Mechanism in SEM

Plant Type	Capacity Payment	Average Price
CCGT	€ 62,044,340	€ 9.2
Natural Gas	€ 4,628,558	€ 7.8
Hydro	€ 3,900,260	€ 8.3
OCGT	€ 12,190,369	€ 8.0
Coal / Oil	€ 63,760,035	€ 7.3
Reheat	€ 55,373,056	€ 7.7
Wind	€ 6,170,379	€ 4.1 ** 11



Outside Market Supports and Influences

- Contracts for Difference
 - Directed Contracts
 - Hedging risk
- REFIT, AER
 - Additional support mechanisms for renewable generation
- Public Service Obligations (PSO)
 - Peat
- Carbon Pricing
 - Carbon regulated to be bid fully in
- Emissions' Trading
 - Grandfathered rights
 - EU trading rules



Overview

- Wind
 - Energy Price approx Euro 74 /MWh of output
 - (based on Jan, Feb, Mar 2008)
 - Capacity Payment approx Euro 11 /MW produced by a windfarm

- Are the market prices bankable?
 - Are they high enough for on shore wind?
 - How long do they need to be to appease investors?
 - Are support mechanisms required indefinitely?



Becoming a participant

- Need a licence
 - CER
- Need a connection
 - Connection Agreement
 - Contestability – Connection provider (ESB Networks)
- Need Metering and Signals
 - ESB Networks/EirGrid
- Need a Use of System Agreement
 - ESB Networks/EirGrid
- Need to Register as a Party and Participant
 - SEMO



Agreements needed as a generator: Participating in the SEM

Controllable	Connected	Metering	Connection Agreement	Use of System
No	Distribution	MRSO	ESB Networks	ESB
Yes	Distribution	MRSO/EirGrid	ESB Networks	ESB
No	Transmission	EirGrid	EirGrid	EirGrid
Yes	Transmission	EirGrid	EirGrid	EirGrid

*** controllable windfarms need metering, availability and dispatch instructions consistent with wind grid code**



Difference between Generator and Supplier Payments and Charges

Generator	Supplier
Energy Market Payments	Energy Market Charges
Constraints	Capacity Market Charges
TUoS or DUoS *	Market Operator Charge
Ancillary Service payments	Imperfections Charge
	Transmission Use of System
	Distribution Use of System
	PSO Levy
	CER Levy
Minimum Collateral Cover	Significant Collateral Cover



SEM Becoming a participant – Registration

Registration Components

Register as a Party

Market Participant Data Provision

Confirm Data Provider System Set Up

Communications Channel Qualification Testing (CCQT)

Legal Accession

Financial Management

□ **Questions and Answers**



markethelpdesk@sem-o.com

Registering Entities – Trading Site Configuration

Trading Site Configuration

PHYSICAL UNITS

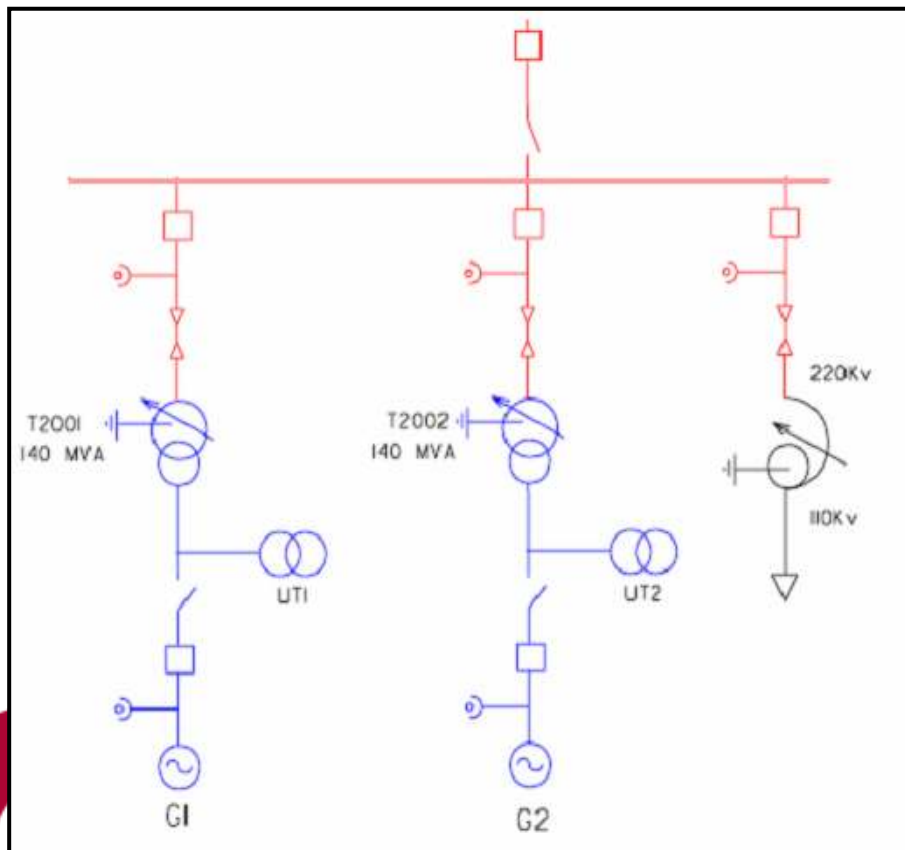

CONFIGURATION

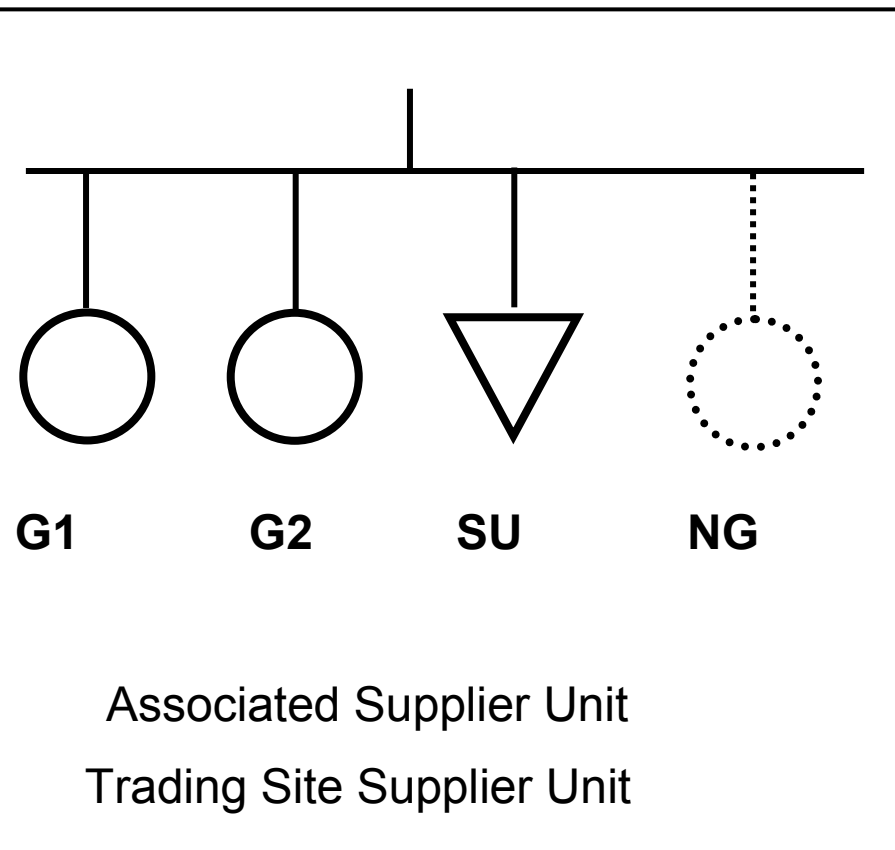

Registering Entities – Trading Site Configuration

Trading Site Configuration

PHYSICAL UNITS

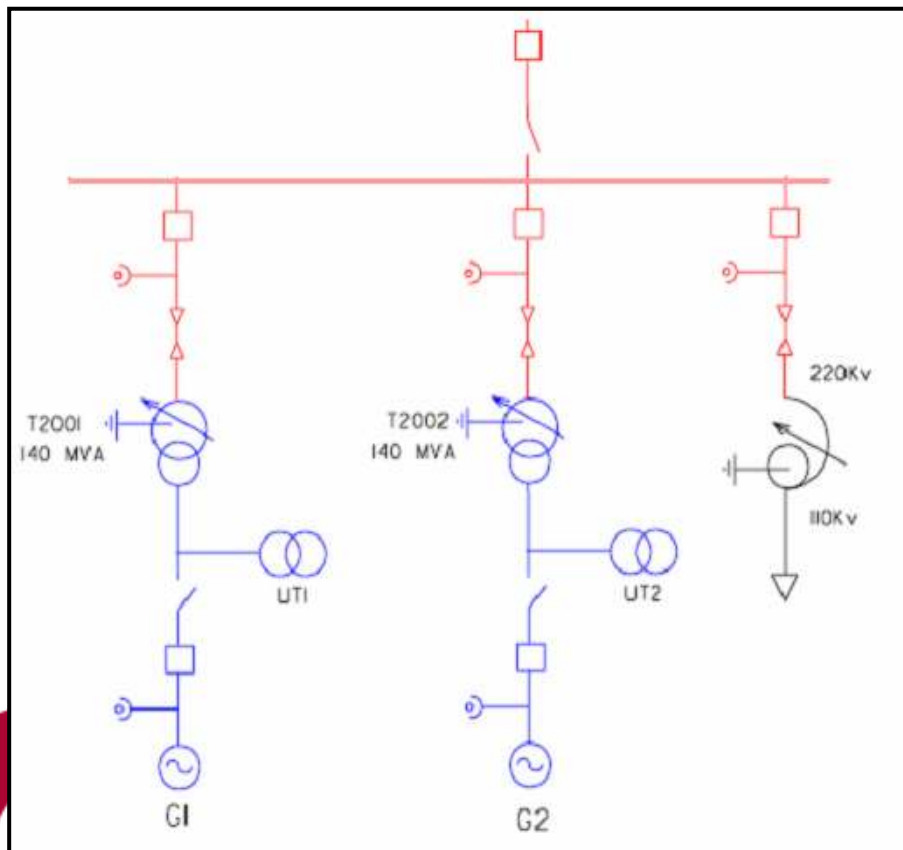

CONFIGURATION

